

**VIII SIMPÓSIO DE ESPECIALISTAS EM PLANEJAMENTO DA OPERAÇÃO E
EXPANSÃO ELÉTRICA**

**VIII SYMPOSIUM OF SPECIALISTS IN ELECTRIC OPERATIONAL AND
EXPANSION PLANNING**

VIII SEPOPE

TWO POWERFUL NETWORK MODELING APPROACHES FOR THE MODAL ANALYSIS OF HARMONIC PROBLEMS

SERGIO L. VARRICCHIO ¹

SERGIO GOMES JR. ¹

NELSON MARTINS ¹

FRANKLIN C. VÉLIZ ²

¹ CEPEL

² FCTJF

PAPER CONTENTS



- ❖ Background
- ❖ Network Modeling Approaches
 - Descriptor System
 - S-Domain – Matrix $\mathbf{Y}(s)$
- ❖ Dominant Pole Algorithm
- ❖ Test System
- ❖ Harmonic Problem
 - Option 1
 - Option 2
- ❖ Remarks and Conclusions

BACKGROUND



❖ Transfer Impedance (Function)

$$z_{ij}(s) = \frac{V_i(s)}{I_j(s)}$$

❖ System Pole

$$z_{ij}(s) = \infty \quad \text{or} \quad \frac{1}{z_{ij}(s)} = 0$$

❖ Transfer Impedance Zero

$$z_{ij}(s) = 0$$

BACKGROUND



- ❖ If $s_k = \sigma_k + j\omega_k$ is a system pole or a transfer impedance zero then $z_{ij}(\sigma_k + j\omega_k) = \infty$ or 0 , respectively, but $z_{ij}(j\omega_k) \neq \infty$ or 0 .
- ❖ ω_k is a parallel resonance frequency (if s_k is a pole) or a series resonance frequency (if s_k is a zero).
- ❖ $|z_{ij}(j\omega_k)|$ has a high impedance value (very close to a local maximum) or a low impedance value (very close to a local minimum) depending on if s_k is a pole or a zero.

BACKGROUND: INFLUENCY OF THE POLE AND ZERO SPECTRA ON THE FREQUENCY RESPONSE

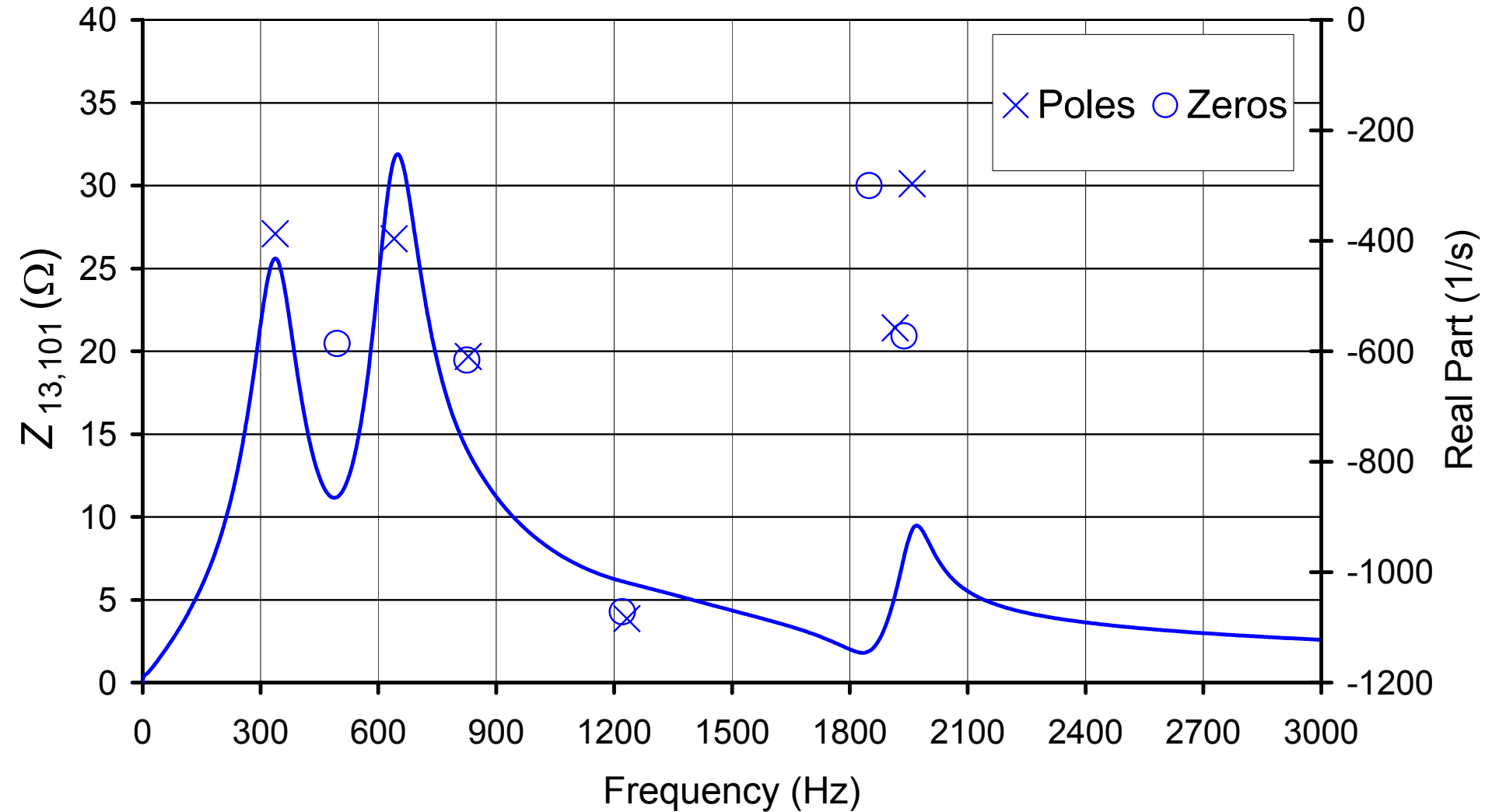

BACKGROUND



- ❖ Harmonic voltage performance of a system depends on the location of its poles and zeros mainly with respect to the characteristic harmonic frequencies.
- ❖ Modal analysis finds poles, zeros and their respective sensitivities to system parameters.
- ❖ Most effective parameter changes in order to reduce harmonic voltage levels.

NETWORK MODELING APPROACHES



- ❖ Descriptor System and Matrix $Y(s)$ approaches allow modal and conventional harmonic analysis of large scale networks.
- ❖ The combined advantages of the two approaches seems to be a powerful computational tool for the solutions of harmonic problems in power systems.

DESCRIPTOR SYSTEM



❖ Main Characteristic

- The circuit equations are written in the time-domain.

❖ Main Advantage

- The system poles and the transfer function zeros (eigenvalues) can be calculated all at once using QZ factorization or one at a time using Newton based algorithm.

❖ Main Disadvantages

- The modeling of frequency dependent parameters is difficult.
- The system matrices have dimensions much larger than the number of system buses.

DESCRIPTOR SYSTEM

RLC Series Branch

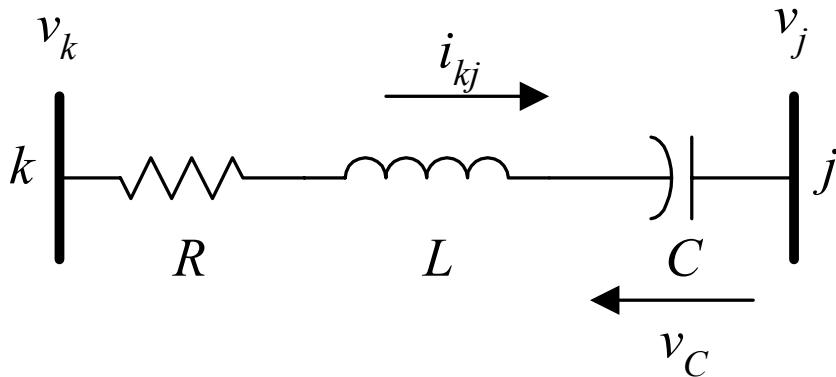

$$v_k - v_j = R i_{kj} + L \frac{di_{kj}}{dt} + v_C$$

$$C \frac{dv_C}{dt} = i_{kj}$$

Element variables = $[v_C, i_{kj}]$

RLC Parallel Branch

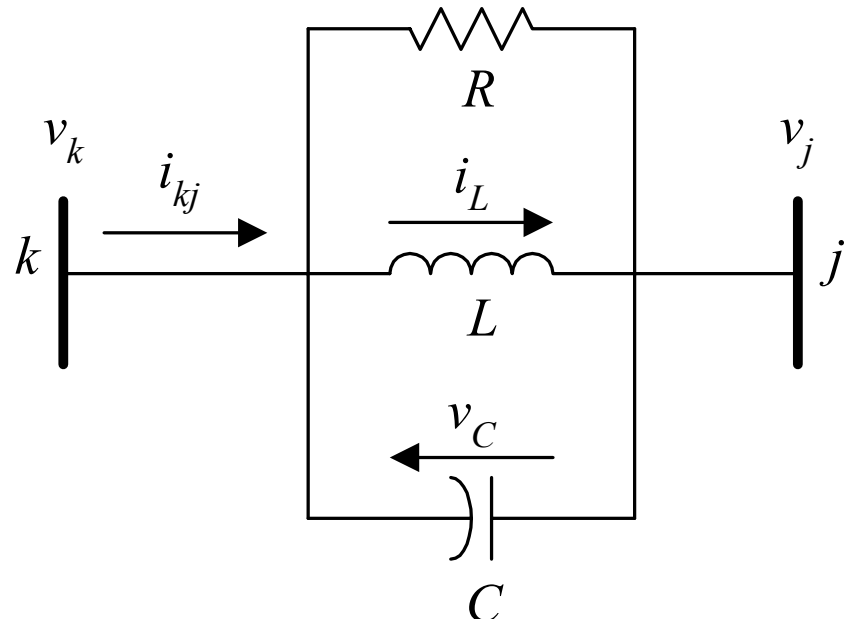

$$\frac{v_C}{R} + i_L + C \frac{dv_C}{dt} = i_{kj} \quad L \frac{di_L}{dt} = v_C$$

$$v_C = v_k - v_j$$

Element variables = $[v_C, i_L, i_{kj}]$

DESCRIPTOR SYSTEM



- ❖ KCL Equations - Kirchhoff's Current Law
 - Interconnect the various network elements

Node k

$$\sum_{m \in \Omega} i_{mk} = 0$$

Ω is the set of all nodes connected to node k

DESCRIPTOR SYSTEM

- ❖ The Interconnection of all system elements yields

$$\left[\begin{array}{c|c} \mathbf{T}_1 & \mathbf{0} \\ \hline \mathbf{0}^T & \mathbf{0}_q \end{array} \right] \left[\begin{array}{c} \dot{\mathbf{x}}_1 \\ \dot{\mathbf{v}}_{nodal} \end{array} \right] = \left[\begin{array}{c|c} \mathbf{A}_1 & \mathbf{A}_2 \\ \hline \mathbf{A}_3 & \mathbf{0}_q \end{array} \right] \left[\begin{array}{c} \mathbf{x}_1 \\ \mathbf{v}_{nodal} \end{array} \right] + \left[\begin{array}{c} \mathbf{0} \\ \mathbf{I} \end{array} \right] \mathbf{i}_{nodal}$$

$$\mathbf{v}_{nodal} = \left[\begin{array}{c|c} \mathbf{0}^T & \mathbf{I} \end{array} \right] \left[\begin{array}{c} \mathbf{x}_1 \\ \mathbf{v}_{nodal} \end{array} \right]$$

$\mathbf{x}_1 \rightarrow$ Vector of all element variables

- ❖ Compact form of the Descriptor System Equations

$$\mathbf{T} \dot{\mathbf{x}} = \mathbf{A} \mathbf{x} + \mathbf{B} \mathbf{u}$$

$$\mathbf{y} = \mathbf{C} \mathbf{x}$$

MATRIX $Y(s)$



❖ Main Characteristic

- Circuit equations are written in the s-domain.

❖ Main Advantages

- Modeling of frequency dependent parameters is very easy.
- System matrices ($Y(s)$ and its derivative with respect to s) have dimensions equal to the number of system buses.

❖ Main Disadvantage

- System poles and the transfer function zeros (eigenvalues) can only be calculated one at a time.

MATRIX $Y(s)$

RLC Series Branch

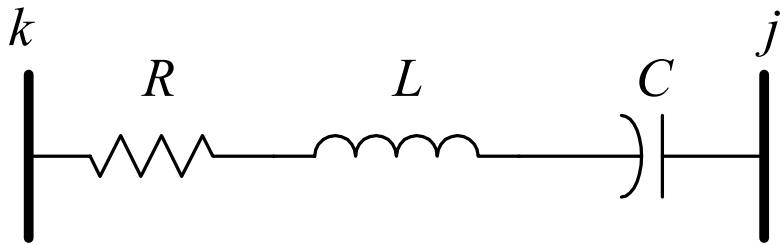

$$y_{series} = \frac{sC}{s^2 LC + sRC + 1}$$

$$\frac{dy_{series}}{ds} = -\frac{(s^2 LC - 1)}{Cs^2} y_{series}^2$$

RLC Parallel Branch

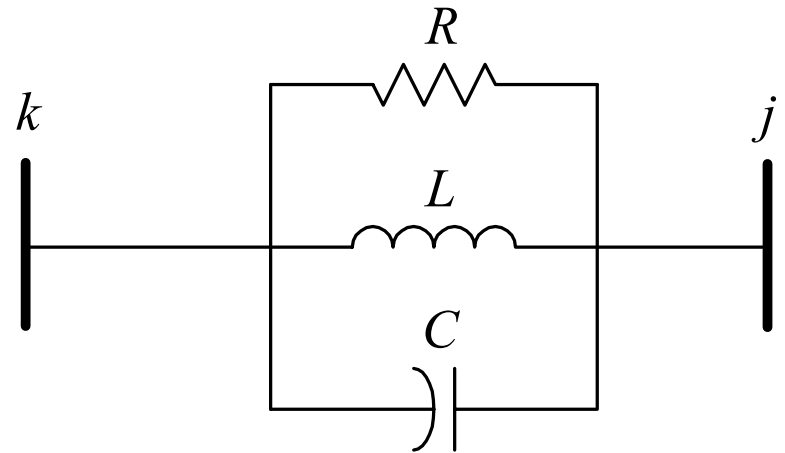

$$y_{parallel} = \frac{1}{R} + \frac{1}{sL} + sC$$

$$\frac{dy_{parallel}}{ds} = C - \frac{1}{s^2 L}$$

MATRIX $\mathbf{Y}(s)$



- ❖ A diagonal element y_{ii} of $\mathbf{Y}(s)$ is equal to the summation of all elementary admittances connected to node i .
- ❖ An off-diagonal element y_{ij} of $\mathbf{Y}(s)$ is equal to the negative of the summation of all elementary admittances connected between the nodes i and j .
- ❖ The derivative matrix of $\mathbf{Y}(s)$ is built using the same rules used to build $\mathbf{Y}(s)$ but using the derivatives of the elementary admittances.

DOMINANT POLE ALGORITHM

Harmonic Impedance

$$z_{ij}(s) = V_i / I_j = \mathbf{c}^t \mathbf{Y}^{-1}(s) \mathbf{b}$$

System Poles

$$1/z_{ij}(s) = 0$$

Newton-Raphson

$$s^{(k+1)} = s^{(k)} + \left(\frac{dz_{ij}}{ds} \right)^{-1} z_{ij}$$

Harmonic Impedance Derivative

$$\frac{dz_{ij}(s)}{ds} = -\mathbf{w}^t \frac{d\mathbf{Y}(s)}{ds} \mathbf{v}$$

Auxiliary Equations

$$\mathbf{Y}(s) \mathbf{v} = \mathbf{b} ; \mathbf{Y}(s)^t \mathbf{w} = \mathbf{c}$$

POLE AND ZERO SENSITIVITIES TO A SYSTEM PARAMETER

The \mathbf{Y} matrix is considered as a function of the complex frequency s and a system parameter p .

Sensitivity Equation

$$\frac{ds_k}{dp_l} = \frac{\mathbf{w}^t \frac{\partial \mathbf{Y}(s, p)}{\partial s} \mathbf{v}}{\mathbf{w}^t \frac{\partial \mathbf{Y}(s, p)}{\partial p} \mathbf{v}} \left| \begin{array}{l} s = s_k \\ p = p_l \end{array} \right.$$

The imaginary part of a pole (or zero) sensitivity is the rate of change of the associate parallel (or series) resonance frequency with respect to a system parameter.

TEST SYSTEM

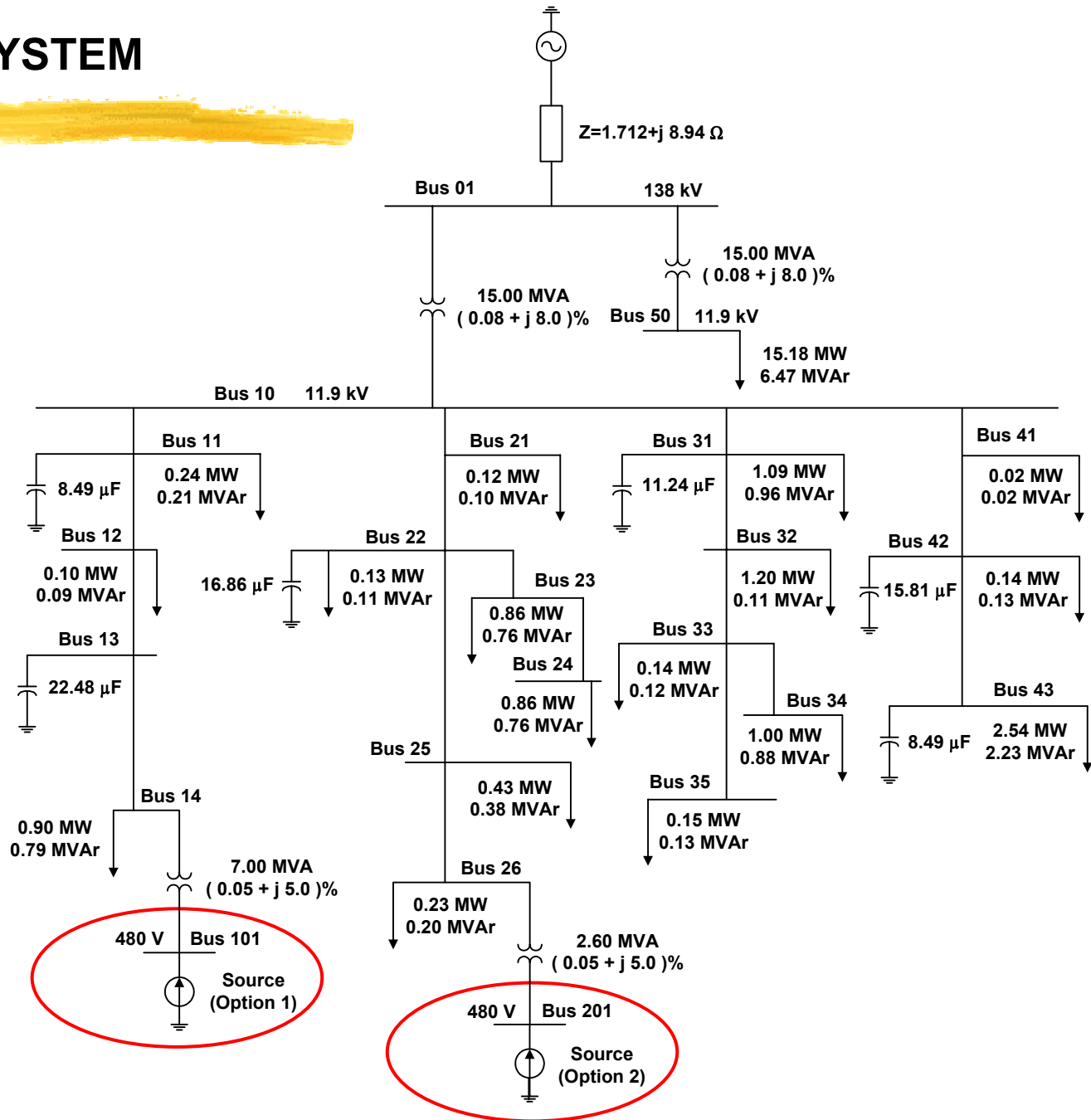

HARMONIC PROBLEM

- ❖ Which is the best bus for placing a 12-pulse industrial rectifier: Bus 101 (Option 1) or Bus 201 (Option 2)
 - Total Current at Fundamental Frequency: 5.5 kA
 - Harmonic Current Components:

h	11	13	23	25
$f(\text{Hz})$	660	780	1380	1500
$I_h(\%)$	9.0	8.0	4.0	4.0

OPTION 1: INFLUENCY OF THE POLE AND ZERO SPECTRA ON THE FREQUENCY RESPONSE

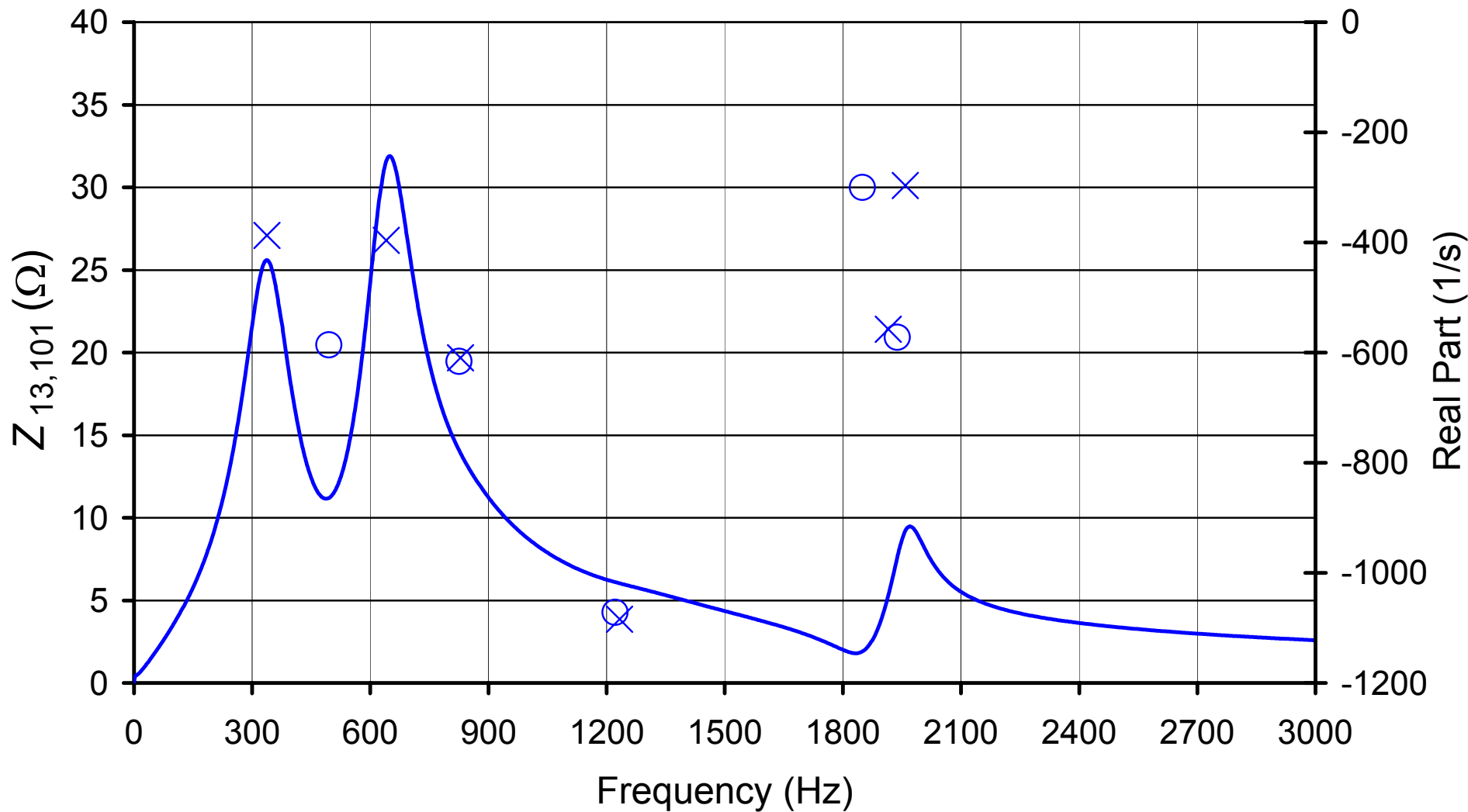

OPTION 1: POLE SENSITIVITIES

Frequency Associated with the Poles and Their Sensitivities (Hz/ μ F) to Capacitor Changes

	P ₁	P ₂	P ₃	P ₄	P ₅	P ₆
f (Hz)→	337	640	829	1233	1916	1959
C_{11}	-1.936	-0.903	0.004	-0.697	0.836	-99.888
C_{13}	-2.731	-7.048	-0.242	-0.541	-0.170	-3.978
C_{22}	-1.682	-1.635	-16.108	-3.294	-0.124	-0.083
C_{31}	-1.387	-0.571	-0.527	-46.357	-1.701	-2.152
C_{42}	-1.815	-3.978	-3.890	-0.286	-25.237	-3.511
C_{43}	-2.036	-6.260	-8.375	-2.971	-63.705	5.768

OPTION 1: ZERO SENSITIVITIES

Frequency Associated with the Zeros of $Z_{101,13}$ and Their Sensitivities (Hz/ μ F) to Capacitor Changes

	Z_1	Z_2	Z_3	Z_4	Z_5
f (Hz)→	495	825	1221	1849	1938
C_{11}	-0.659	-0.109	-1.981	-99.619	-3.721
C_{13}	0.000	0.000	0.000	0.000	0.000
C_{22}	-4.121	-14.941	-3.814	-0.242	0.004
C_{31}	-2.588	-0.550	-44.867	-5.162	0.200
C_{42}	-5.207	-4.578	-0.344	0.918	-29.679
C_{43}	-6.786	-9.716	-3.307	-4.331	-53.585

OPTION 1: POLE SHIFT EFFECTS

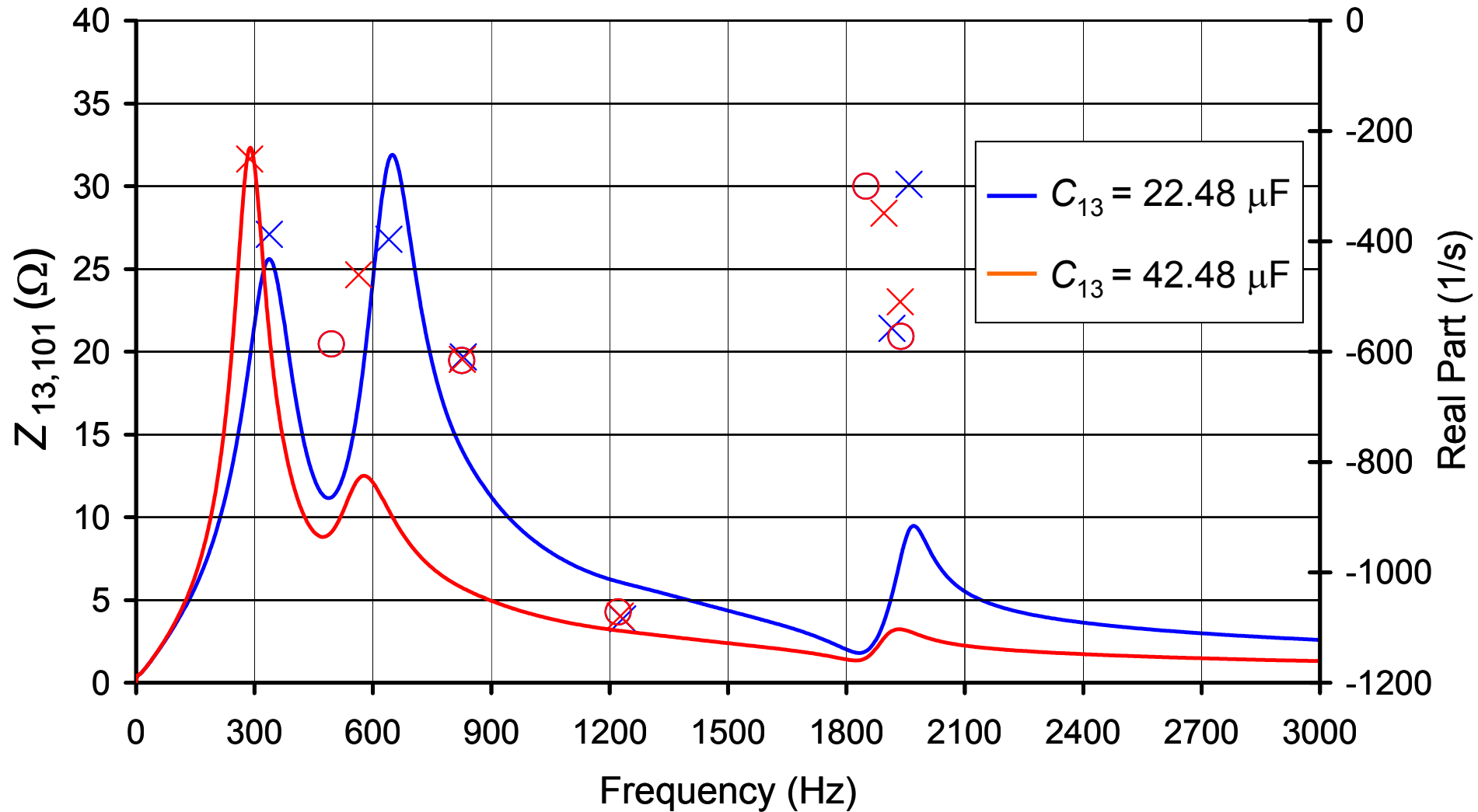

OPTION 1: PROPOSED SOLUTION

Harmonic Voltage Distortion
Spectrum at Bus 13

Harmonic Order	Original System (%)	Proposed Solution (%)	Limits (%)
11	9.15	2.78	3.5
13	4.33	1.65	3.0
23	0.662	0.350	1.5
25	0.563	0.309	1.5

OPTION 2: INFLUENCY OF THE POLE AND ZERO SPECTRA ON THE FREQUENCY RESPONSE

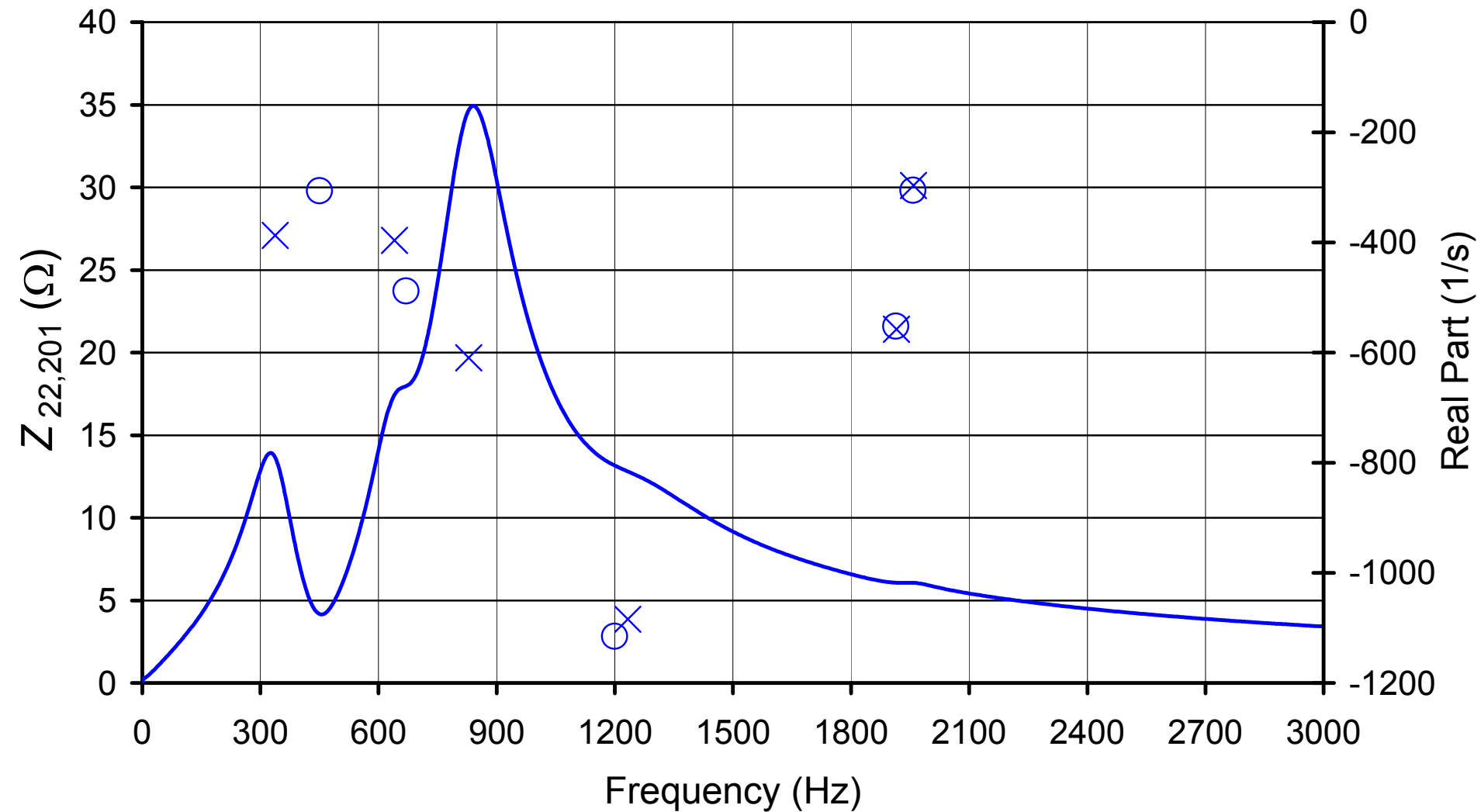

OPTION 2: POLE SENSITIVITIES

Frequency Associated with the Poles and Their Sensitivities (Hz/ μ F) to Capacitor Changes

	P ₁	P ₂	P ₃	P ₄	P ₅	P ₆
f (Hz)→	337	640	829	1233	1916	1959
C_{11}	-1.936	-0.903	0.004	-0.697	0.836	-99.888
C_{13}	-2.731	-7.048	-0.242	-0.541	-0.170	-3.978
C_{22}	-1.682	-1.635	-16.108	-3.294	-0.124	-0.083
C_{31}	-1.387	-0.571	-0.527	-46.357	-1.701	-2.152
C_{42}	-1.815	-3.978	-3.890	-0.286	-25.237	-3.511
C_{43}	-2.036	-6.260	-8.375	-2.971	-63.705	5.768

OPTION 2: ZERO SENSITIVITIES

Frequency Associated with the Zeros of $Z_{201,22}$ and Their Sensitivities (Hz/ μ F) to Capacitor Changes

	Z_1	Z_2	Z_3	Z_4	Z_5
f (Hz)→	450	670	1199	1914	1958
C_{11}	-3.018	-0.269	-0.900	-0.700	-98.199
C_{13}	-6.258	-3.683	-0.798	-0.257	-3.908
C_{22}	0.000	0.000	0.000	0.000	0.000
C_{31}	-1.063	-0.735	-47.545	-1.959	-2.180
C_{42}	-1.892	-7.970	-0.552	-24.396	-4.303
C_{43}	-2.227	-13.092	-4.552	-63.444	5.446

OPTION 2: POLE SHIFT EFFECTS

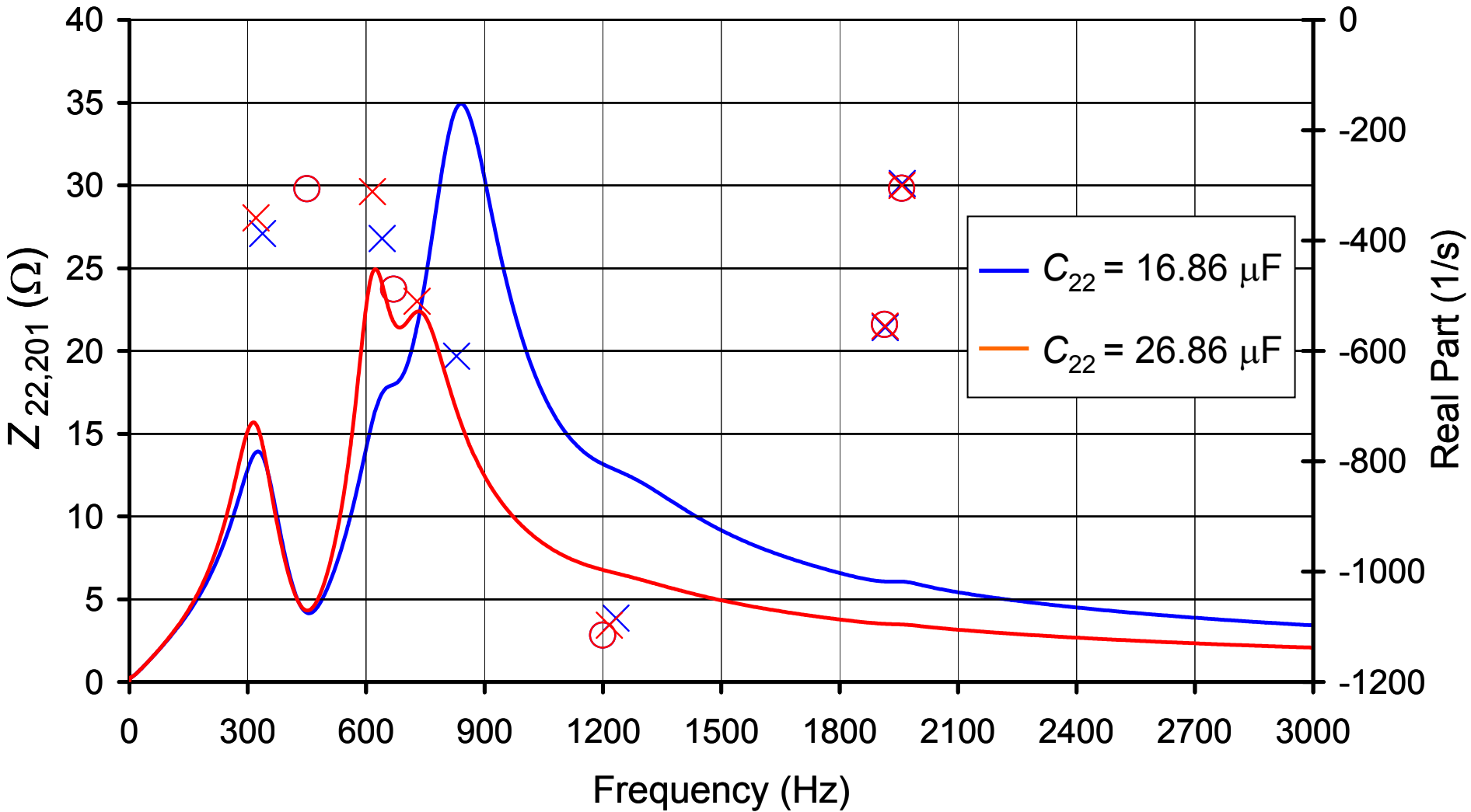

OPTION 2: POLE SENSITIVITIES

Frequency Associated with the Poles and Their Sensitivities (Hz/ μ F) to Capacitor Changes for $C_{22}=26.86 \mu$ F

	P ₁	P ₂	P ₃	P ₄	P ₅	P ₆
f (Hz)→	321	616	729	1216	1915	1958
C_{11}	-1.591	-1.284	-0.007	-0.808	0.312	-99.316
C_{13}	-2.175	-7.587	-0.151	-0.668	-0.201	-3.955
C_{22}	-1.677	-3.275	-5.358	-0.845	-0.044	-0.024
C_{31}	-1.185	-0.240	-0.060	-47.422	-1.799	-2.172
C_{42}	-1.505	-1.213	-6.941	-0.406	-24.920	-3.808
C_{43}	-1.669	-1.789	-12.465	-3.737	-63.681	5.715

OPTION 2: ZERO SENSITIVITIES

Frequency Associated with the Zeros of $Z_{201,22}$ and Their Sensitivities (Hz/ μ F) to Capacitor Changes for $C_{22}=26.86 \mu$ F

	Z_1	Z_2	Z_3	Z_4	Z_5
f (Hz)→	450	670	1199	1914	1958
C_{11}	-3.018	-0.269	-0.900	-0.700	-98.199
C_{13}	-6.258	-3.683	-0.798	-0.257	-3.908
C_{22}	0.000	0.000	0.000	0.000	0.000
C_{31}	-1.063	-0.735	-47.545	-1.959	-2.180
C_{42}	-1.892	-7.970	-0.552	-24.396	-4.303
C_{43}	-2.227	-13.092	-4.552	-63.444	5.446

OPTION 2: POLE SHIFT EFFECTS

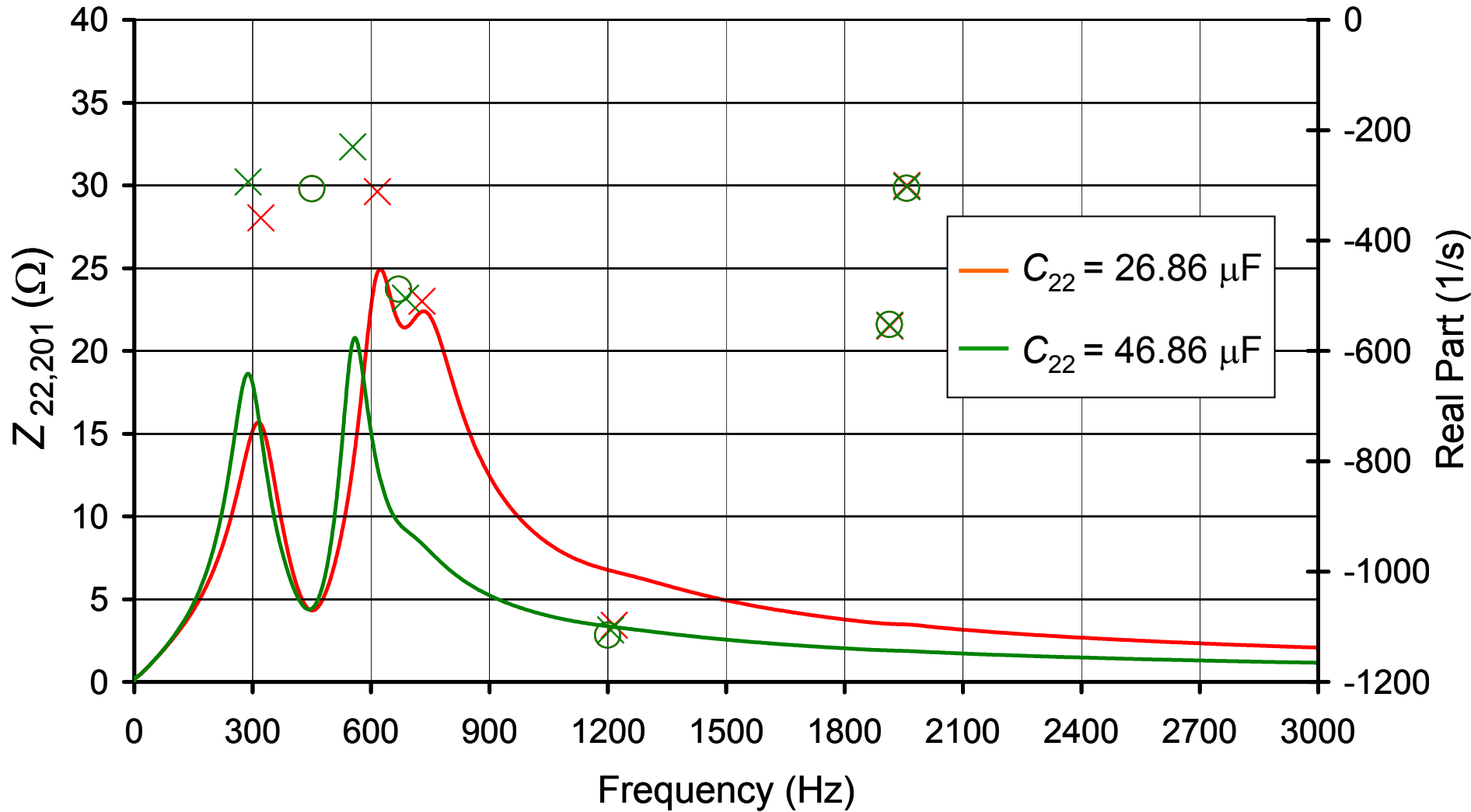

OPTION 2: FINAL RESULT

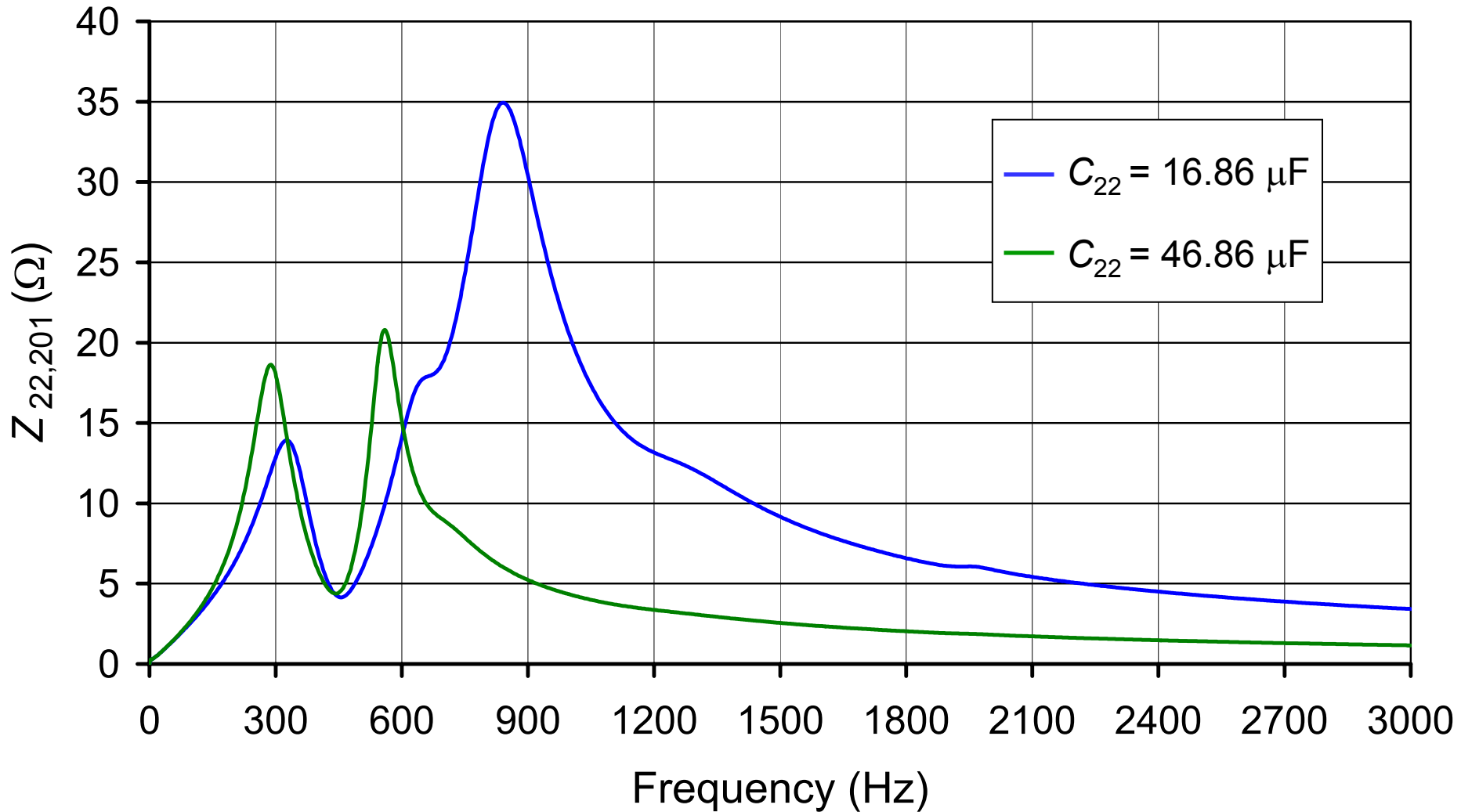

OPTION 2: PROPOSED SOLUTION



Harmonic Order	Original System (%)	Proposed Solution (%)	Limits (%)
11	5.20	2.89	3.5
13	7.48	1.85	3.0
23	1.40	0.368	1.5
25	1.18	0.330	1.5

REMARKS

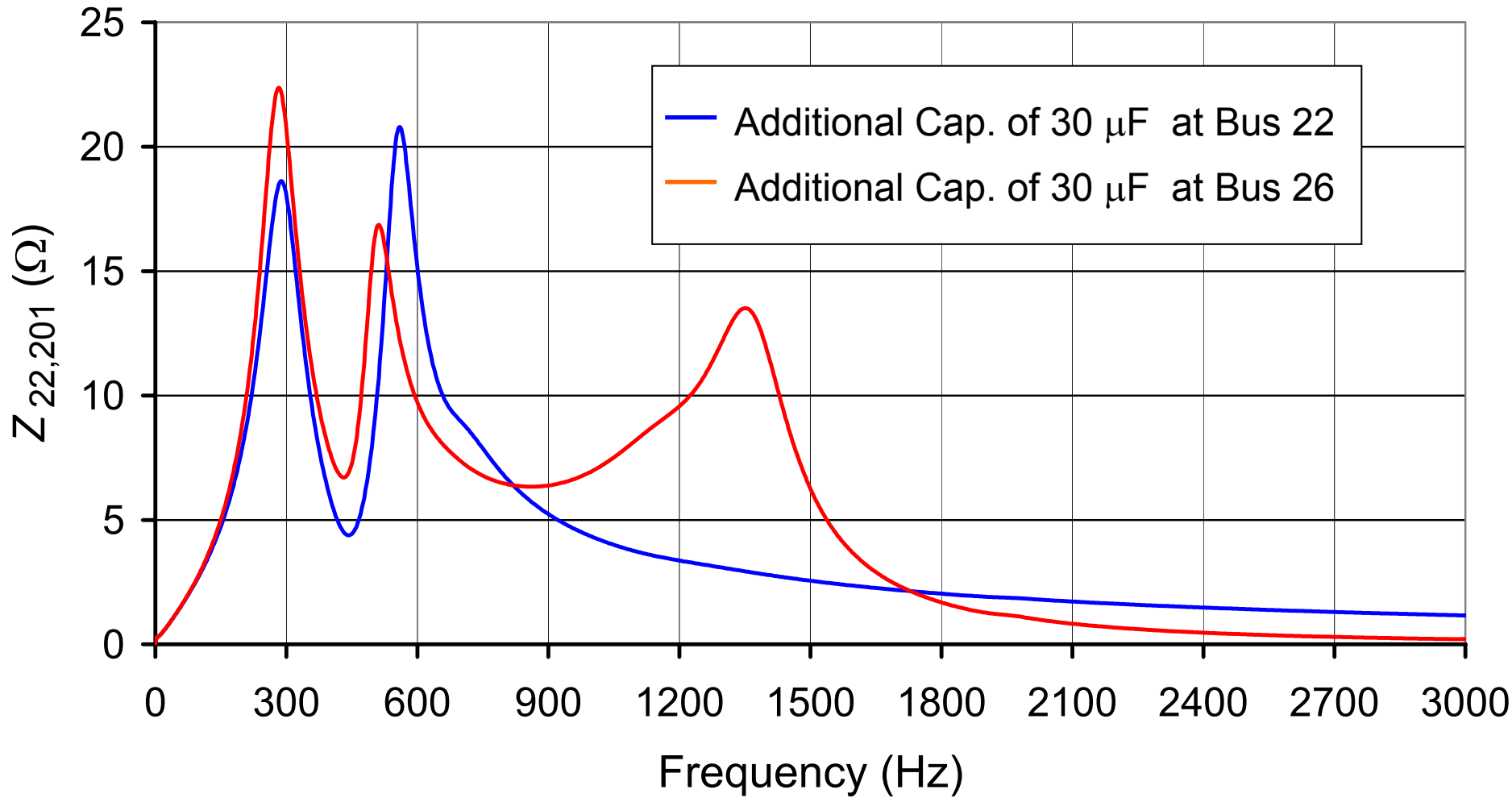

CONCLUSIONS



- ❖ $Y(s)$ is a natural evolution of the conventional $Y(j\omega)$ approach.
- ❖ $Y(s)$ allows obtaining all the results produced by the $Y(j\omega)$ approach. Additionally, modal analysis can be performed using $Y(s)$.
- ❖ Descriptor System approach can be used as a powerful complement of $Y(s)$, since it allows the computation of the complete set of system poles and transfer function zeros at once.
- ❖ This paper is a tutorial example of using modal analysis to improve harmonic voltage distortions in electrical systems.

CONCLUSIONS



- ❖ Basically there are three forms of improving the harmonic performance of a system: Filtering harmonic currents, improving the performance of nonlinear loads and system modifications. This paper is a contribution for the third form.
- ❖ System modifications seems to be particularly suitable for reducing harmonic distortions in larger systems which have several and spread nonlinear loads.